

# MULAG

Innovative Technologies for Roadside Maintenance



## Verge Mower

# MRM 300

Unimog



Mercedes-Benz  
Unimog ExpertPartner

In the context of the new partnership model for equipment body manufacturers, MULAG Fahrzeugwerk was one of the first to be honoured by Daimler AG with the **highest partnership level Mercedes-Benz Unimog ExpertPartner**.

In this closer cooperation which is exemplary for the joint development of equipment, drive concepts and interfaces in the best quality, **MULAG has fulfilled the requirements to the highest level in the areas of quality, sales, service and technology**, which Mercedes-Benz Special Trucks sets for body manufacturers in the field of individual body solutions.

## MULAG Verge Mower MRM 300

- Comfortable one-man-operation
- Varied fields of application
- Automatic parking system

### Road maintenance – simple and flexible

Our front mounted mowing equipment is attached to the quick-change-system of the Unimog and **well suited to one-man-operation**, in particular when used in conjunction with the rear mounted boom system. The mower can be used **for both right-hand and left-hand operation**. The drive is provided either via the vehicle power hydraulic system or via front PTO-shaft.

The verge mower is ideal for near roadside mowing work. Due to its low height, this mowing equipment is suitable for working underneath crash-barriers.

The **control through sensor bar automatically regulates** the cutting shaft speed according to the vehicle speed. An automatic pressure relief system minimises the ground pressure of the mowing head. The special construction of the safety mowing shaft minimizes the danger of ejected material.

### Control system m|control

The modular conception of the individual control components provides the operator with maximum flexibility. For each vehicle and product, he has the possibility to choose between different control elements and determine the place where they have to be mounted in the cab, which means optimum solutions for the professional use of the mower.

The CAN-bus system makes the integration of control components easier and more reliable – Through this elaborate bus technology – specially designed for the automotive sector – the user benefits from decisive advantages in operation and service of the mower.



# MRM 300 – Cutting Shafts

Our Verge Mower can be equipped with 2 types of cutting shaft:

- the approved safety shaft with its optimised features
- the flail shaft with its unique cutting properties

Both versions are highly convincing.

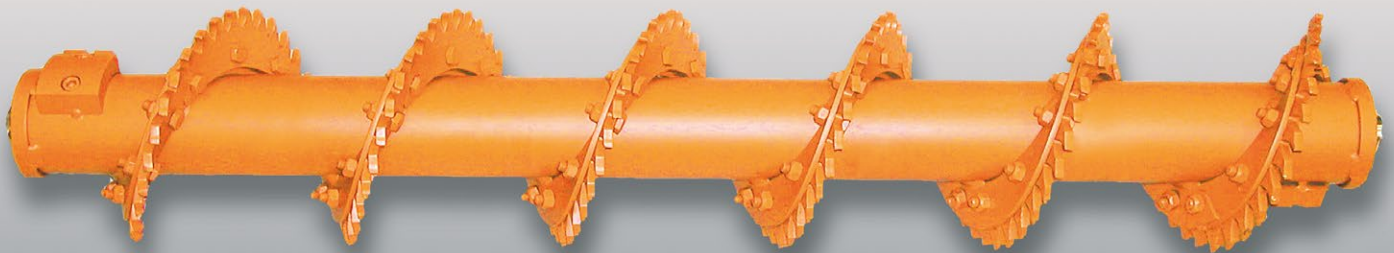

## Safety Shaft



<b>Cutting width</b>	1.2 m
<b>Spiral length</b>	200 mm
<b>Number of segments</b>	18 pieces
<b>Speed of rotation</b>	4800 rpm

- The shaft concept reduces projections – increasing safety at work.
- Less segments (18 instead of 24) – reducing wearing costs
- Life span increased through heattreated wearing parts.

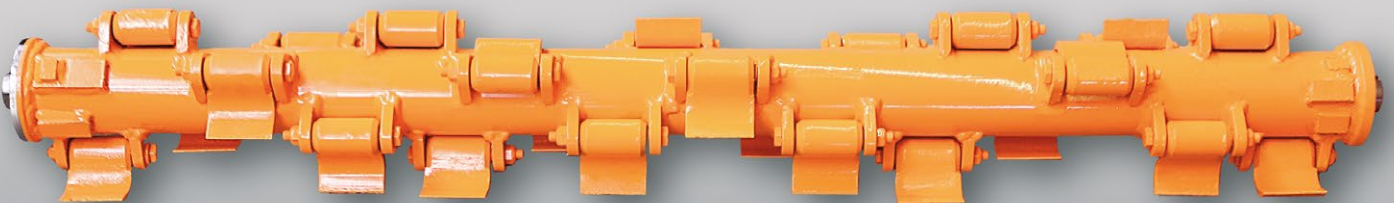

<b>Cutting width</b>	1.2 m
<b>Number of flails</b>	24 pieces
<b>Speed of rotation</b>	3000 rpm

## Flail Shaft

- Improved security against projections thanks to a cutting concept with stronger flails.
- Great mulching results

## MULAG – the answer to all questions in the field of roadside maintenance

The modular concept of MULAG power arms and its wide range of working attachments make their use economical and efficient: All tasks of road maintenance can be handled in a way that is both fast and flexible.

The high quality materials, workmanship and intelligent design reduce equipment down-time and avoid extended repair times.

At MULAG we deliver convincing solutions for all roadside maintenance tasks.

### Technical Data MRM 300

<b>Suitable to</b>	SBU / U 300 - U 500 / U 218 - U 530
<b>Type of fitting</b>	Front mounting plate, size 3/5
<b>Reach</b>	up to 3 m
<b>Drive</b>	- Vehicle power hydraulic system - Front PTO-shaft
<b>Safety cut-off system</b>	Electric switch on/off within 4 sec.
<b>Control</b>	- electrohydraulic control with mowing head relief system - speed-related automatic obstacle detector - Automatic parking system



Verge mower MRM 300 in transport position

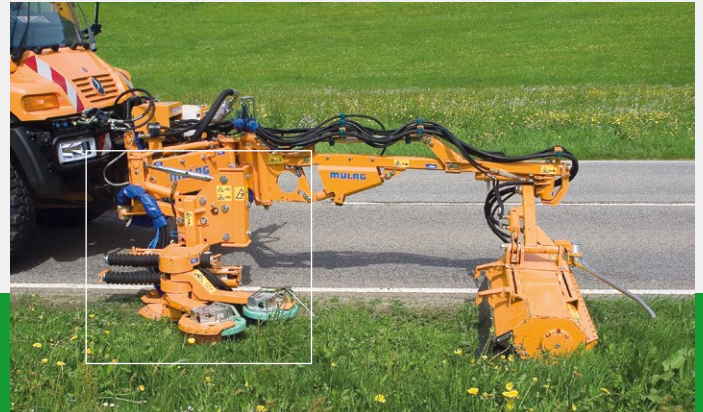

Easy extendible with a reflexion post mower MLM 200

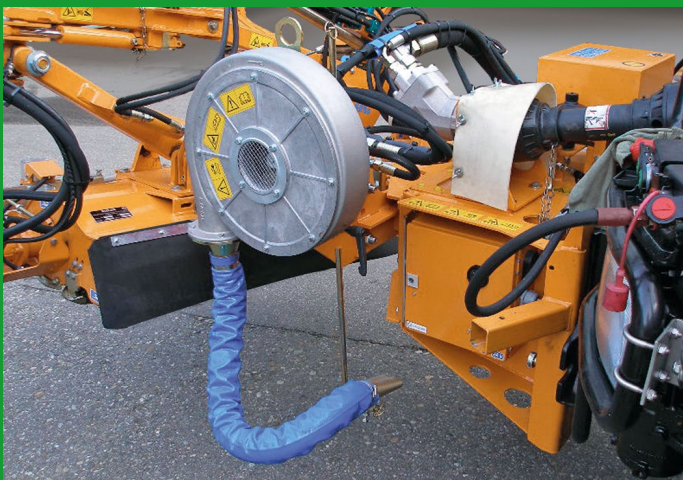

Optional pressure blowing system for effective road cleaning

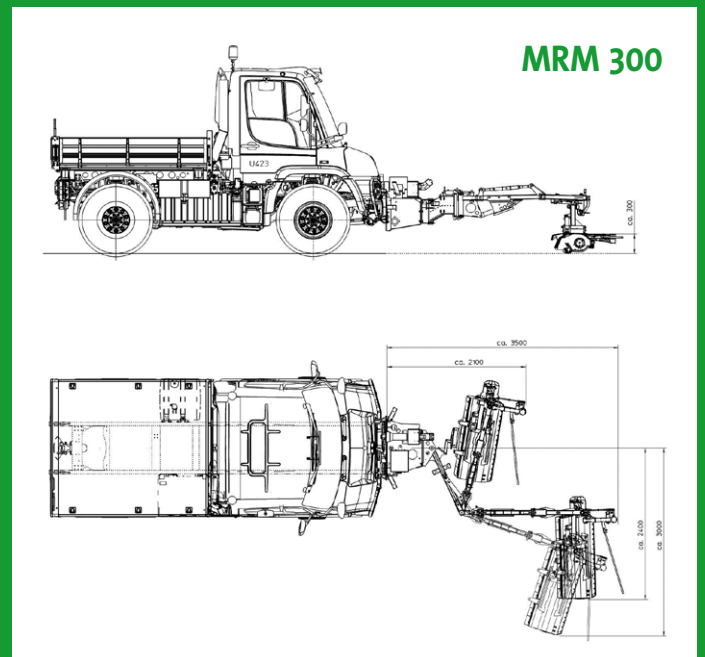

Dimensions and range of the MRM 300

Distributor

Manufacturer

# MULAG

MULAG Fahrzeugwerk  
Heinz Wössner GmbH u. Co. KG  
Gewerbestr. 8  
77728 Oppenau  
Germany

Tel. +49 7804 913-0  
Fax +49 7804 913-163  
E-mail [info@mulag.com](mailto:info@mulag.com)  
Web [www.mulag.com](http://www.mulag.com)

